

ITEM NO.	DESCRIPTION	QTY.
1	SUBPLATE	1
2	ADJUSTABLE MOUNTING PLATE, LARGE FORMAT	1
3	STAINLESS STEEL BEAKER, 500ML, Ø85MM X 110MM(H)	1
4	BEAKER HOLD DOWN BRACKET, LOWER	3
5	BEAKER HOLD DOWN BRACKET, UPPER	3
6	ADHESION/COHESION PROBE W/ 1.50 Ø PHENOLIC HEAD AND MALE JAM-NUT COUPLING	1

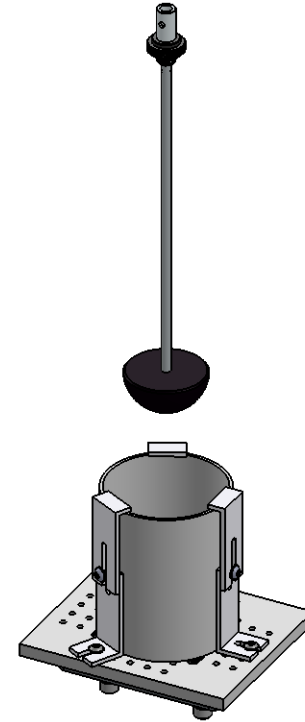
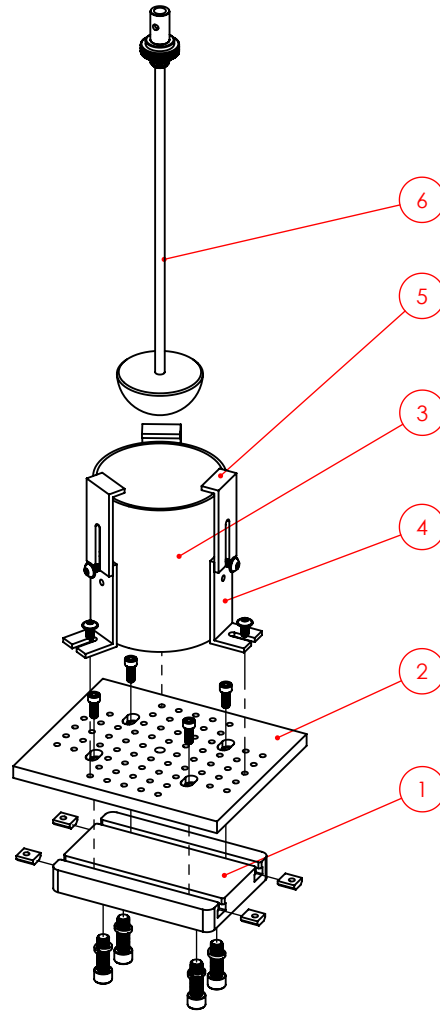

MATERIAL	TOLERANCES DIMENSIONS ARE IN INCHES TOLERANCES: FRACTIONAL ± ANGULAR: MACH ± BEND ± TWO PLACE DECIMAL ± THREE PLACE DECIMAL ±	DRN	1/3/2020	DFM	<b>OAKLAND</b> INSTRUMENT CORPORATION	THE INFORMATION HEREIN IS CONFIDENTIAL AND OUR PROPERTY. IT MAY NOT BE REPRODUCED OR COMMUNICATED TO OTHERS WITHOUT OUR PERMISSION. IT MUST BE USED BY THE RECIPIENT ONLY FOR THE SPECIFIC PURPOSE FOR WHICH IT IS ISSUED, AND IS RETURNABLE UPON REQUEST.
FINISH		CKD	1/3/2020	NAS		
					<b>ADHESION/COHESION          FIXTURE ASSEMBLY</b>	
		SIZE	DWG. NO.		REV	
		<b>A</b>				
		SCALE: 1 : 5	C:\Users\Oakland\Desktop\PRODUCT DEVELOPMENT\FIXTURES\ADHESION COHESION FIXTURE\		SHEET 1 OF 1	